

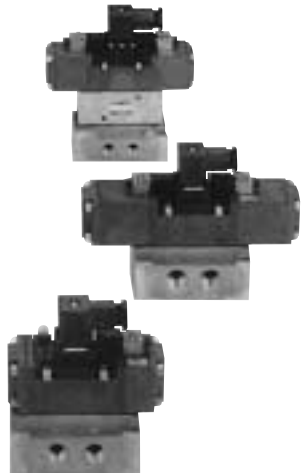
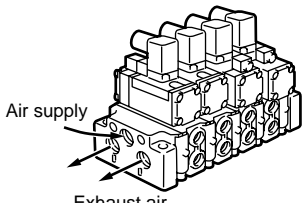
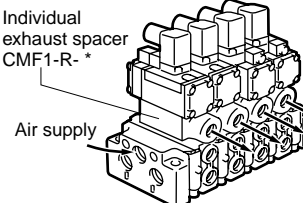
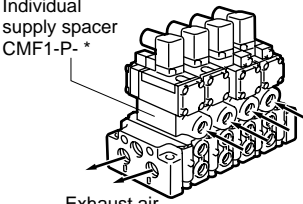
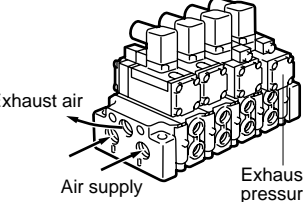
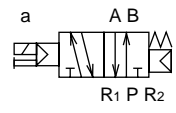
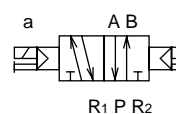
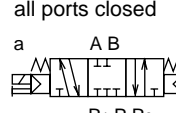
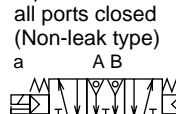
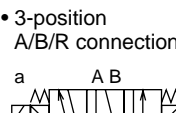
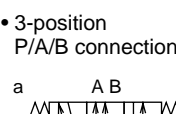
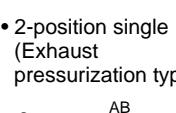
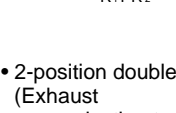

Series/appearance		Position No. of solenoid JIS symbol	Valve faculty		Voltage
Discrete valve	Individual wiring type manifold		Applicable cylinder bore size	Effective sectional area (mm ²)	
PV5-6 5 port valve 	<ul style="list-style-type: none"> • Common exhaust method  Air supply Exhaust air • Individual exhaust method Individual exhaust spacer CMF1-R- *  Air supply Exhaust air • Individual supply method Individual supply spacer CMF1-P- *  Air supply Exhaust air • Common method  Exhaust air Air supply Exhaust pressurization type 	<ul style="list-style-type: none"> • 2-position single  a A B R₁ P R₂ • 2-position double  a A B b R₁ P R₂ • 3-position all ports closed  a A B b R₁ P R₂ • 3-position all ports closed (Non-leak type)  a A B b R₁ P R₂ • 3-position A/B/R connection  a A B b R₁ P R₂ • 3-position P/A/B connection  a A B b R₁ P R₂ • 2-position single (Exhaust pressurization type)  a AB R₁ P R₂ • 2-position double (Exhaust pressurization type)  a AB b R₁ P R₂ 	MAX. 100 dia.	20 to 28	AC100V AC200V DC 12V DC 24V

ISO size 1

ISO size 2

ISO size	Size ①					Size ②								
	Discrete: PV5-6 series Effective sectional area (mm ²): 25 to 28 Manifold: CMF1 series					Discrete: PV5-8 series Effective sectional area (mm ²): 50 to 63 Manifold: CMF2 series								
Sub base														
	Model No.	Electrical connection type	Port size			Model No.	Electrical connection type	Port size		Model No.	Electrical connection type	Port size		
			P/A/B	R1/R2					P/A/B	R1/R2			P/A/B	R1/R2
	CB1-A02	Side porting	Rc1/4	Rc3/8		CB2-A03	Side porting	Rc3/8	Rc1/2	CB2-B03	Back porting	Rc3/8	Rc1/2	
	CB1-A03		Rc3/8			CB2-A04		Rc1/2		CB2-B04		Rc1/2		
	CB1-B02	Back porting	Rc1/4			CB2-A06		Rc3/4	Rc3/4	CB2-B06		Rc3/4	Rc3/4	
CB1-B03		Rc3/8												
Manifold	Page 666					Page 670								
Base specifications					Base specifications									
Series	Descriptions		Specifications			Series	Descriptions		Specifications					
CMF1 Series	Station #		1 to 10 stations (When a control unit is integrated, control unit equivalent to 2 station)			CMF2 Series	Station #		1 to 10 stations					
	Port size	Port A/B	Rc 1 / 4, 3 / 8				Port size	Port A/B	Rc 3 / 8, 1 / 2					
		Port P/R1/R2	Rc 3 / 8, 1 / 2					Port P/R1/R2	Rc 1 / 2, 3 / 4					
Option	Control unit		Air filter (manual drain/automatic drain) Regulator/air release valve			Option	Individual supply spacer		CMF2-P- *					
	Individual supply spacer		CMF1-P- *				Individual exhaust spacer		CMF2-R- *					
	Individual exhaust spacer		CMF1-R- *				Masking plate		CM2-00					
	Masking plate		CM1-00				Spacer type regulator		CMF2-SR-A B					
	Spacer type regulator		CMF1-SR-A B				Air pilot check valve		CMF2-PC					
	Air pilot check valve		CMF1-PC											
Manifold structure					(As an option, CMFZ type, combination of CMF1 and CMF2, is available)									
1	Common exhaust method				1	Common exhaust method								
2	Individual exhaust method				2	Individual exhaust method								
3	Individual supply method				3	Individual supply method								
4	Multi-pressure air supply method				4	Multi-pressure air supply method								
5	Individual supply/exhaust method				5	Individual supply/exhaust method								
6	Back porting method				6	Back porting method								

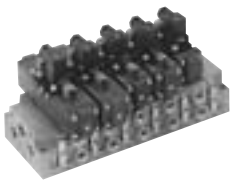

4SA/B0
4SA/B1
4GA/B
MN4GA/B
4GA/B (master)
MN3S0/
MN4S0
4TB
4L2-4/
LMF0
4KA/B
4F
PV5/
CMF
3MA/B0
3PA/B
P/M/B
NP/NAP/
NVP
4F**0E
HMV/
HSV
Uniwire
system
SKH
PCD/
FS/FD
5 port pilot operated valve

Electric connection circuit diagram

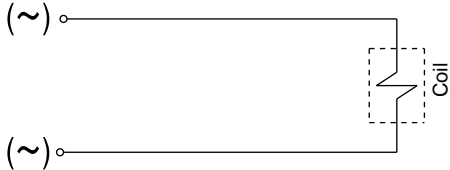
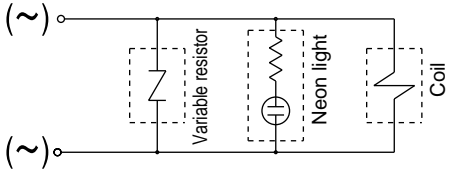
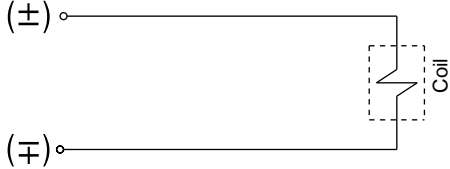
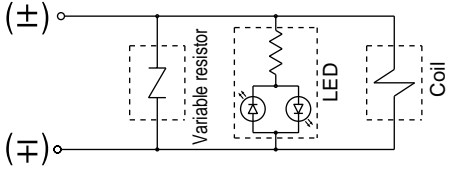
Electric connection (wiring method)	
Blank	N
None	Light/surge suppressor
<p>AC</p> 	<p>AC</p> 
<p>DC</p> 	<p>DC</p> 

- Variable resistor is used for surge suppressor.